

# SILENTMASTER®

MANUFACTURED BY  
**MD**  
CENTRAL VACUUMS

# S560r

#S1154AD 120 VOLT

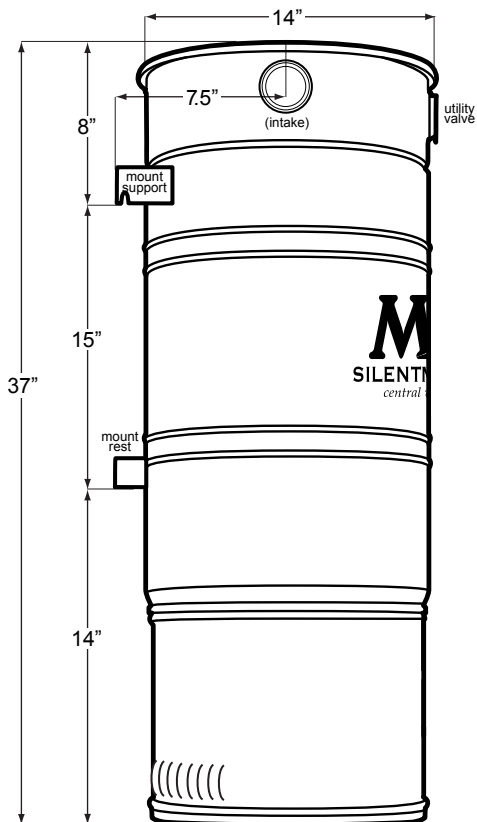

SIDE VIEW

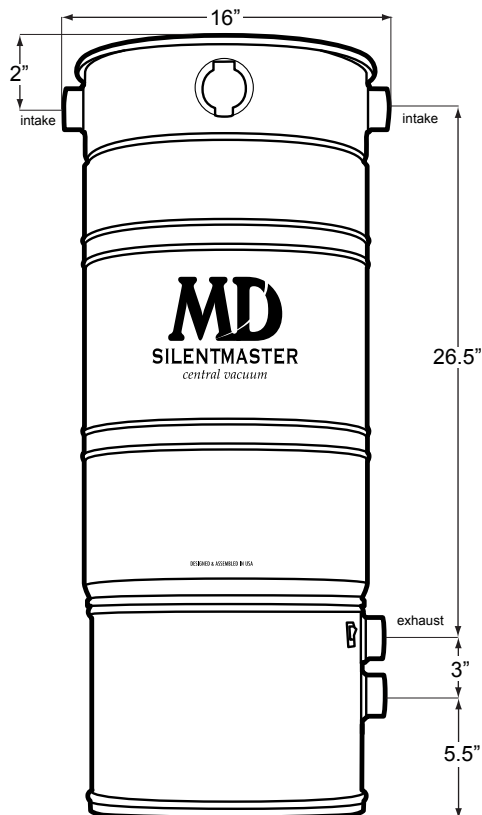

FRONT VIEW

**PERFORMANCE**

- Sealed Vacuum . . . . . 138.9"
- CFM . . . . . 125
- Air Watts . . . . . 557
- Volts . . . . . 120
- Amperage . . . . . 16.8
- Quietness . . . . . 62dBA
- Coverage . . . . . 8,000 ft<sup>2</sup>

\*Recommended home size can be higher or lower when considering these factors: altitude, hours of use, complexity of pipe installation, distance of furthest inlet, noise level, type and size of filtration, and budget.

**FEATURES**

- Motor: Single 2-stage radial bypass motor producing high CFM and waterlift.
- Filtration: HyperFlow™ disposable 12-gallon bag. Closed microfilter bag available.
- Intakes: Right & left intakes. Utility valve.
- Construction: Durable powder-coated all steel body.
- Overload: Heat protection resettable minibreaker.
- Warranty: 12 Years Transferable + Lifetime.
- Dims/Weight: 14" Diameter, 37" Tall, 42 lbs.
- Accessories: All MD accessories and kits are compatible and are sold separately.
- Optional: Air Relief Valve, Mufflers. Closed bag filtration.

**INSTALLATION**

- Electrical: 120V - 50/60HZ, 20 amp circuit. Separate circuit recommended. 6' Cord with standard plug fits NEMA 5-20R receptacle.
- Mounting: Two-stud 17" wide bracket. Easy to hang and remove. Left/right variable positioning. Mount 6" off ground. Leave 24" above unit.
- Venting: Exterior venting not necessary. 30ft maximum dual line if venting.

<b>PROJECT</b>	<b>LOCATION</b>
<b>DEALER</b>	<b>DATE / PRICE</b>



Designed & Assembled in USA

[WWW.BUILTINVACUUM.COM/SILENT-MASTER](http://WWW.BUILTINVACUUM.COM/SILENT-MASTER)

M.D. Manufacturing, Inc. 800.525.2055  
34970 McMurtrey Ave. 661.283.7550  
Bakersfield, CA 93308 FAX 661.283.7554